











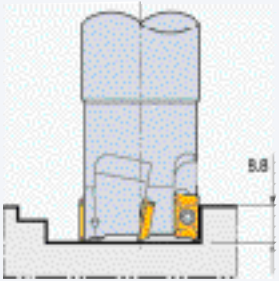





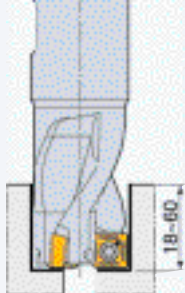

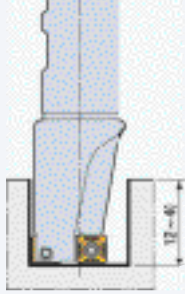
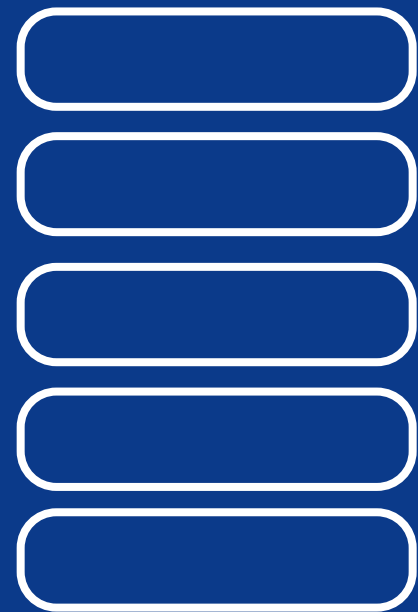
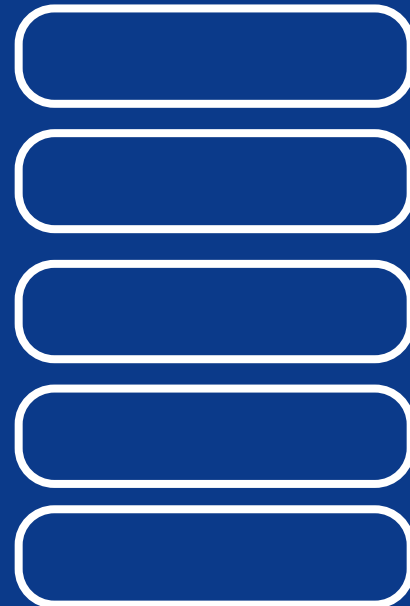

<p>TE90AD-□□□□ -09 신제품</p>   <p>ADKT 0903 PER-ML C14</p>	 <p>• : 90° C31</p>	<ul style="list-style-type: none"> • : Ø10 ~ Ø40mm • 가, 가, 가 (Ramping)가 • 가 가 • 가 (Long Type: -L)
<p>TE90AP-□□□□ -17 신제품</p>   <p>APKT1705PER-M APKT1705PER-EM C14</p>	 <p>• : 90° C32</p>	<ul style="list-style-type: none"> • : Ø20 ~ Ø40mm • 가, 가, 가 (Ramping)가 • 가 (Long Type: -L)
<p>TSF-□□□□ 신제품</p>   <p>XOMT 060204 C28</p>  <p>SPMG/T 090408 SPMG/T 110408 SPMG/T 140508 C25</p>	 <p>• : 90° C33</p>	<ul style="list-style-type: none"> • : Ø12 ~ Ø50mm • (Spot Facing) • (Counter Boring) • (Plunging) • 가
<p>TDM-□□□□ 신제품</p>   <p>XOMT 060204 C28</p>  <p>SPMG/T 090408 SPMG/T 110408 SPMG/T 140508 C25</p>	 <p>• : 90° C34</p>	<ul style="list-style-type: none"> • : Ø12 ~ Ø50mm • 가 (Drill-Mill) • 가

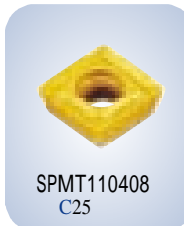
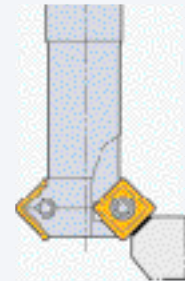

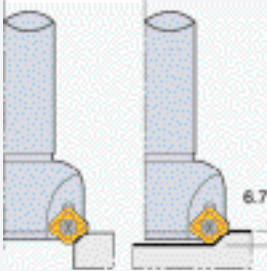

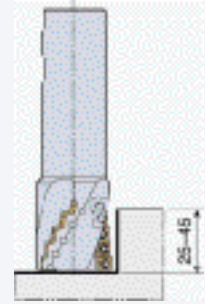

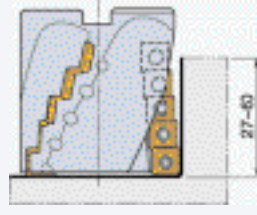

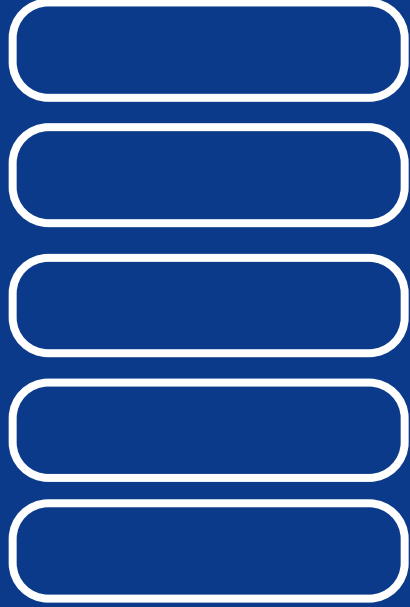

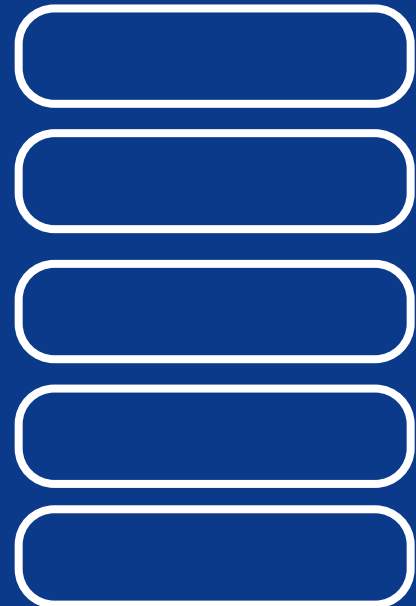

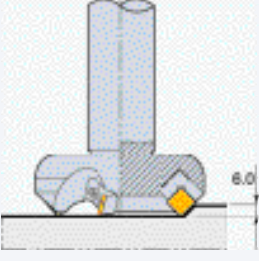

<p>TCF-□□□ -11 신제품</p>   <p>SPMT110408 C25</p>	 <ul style="list-style-type: none"> • : 15°~35° <p>C35</p>	<ul style="list-style-type: none"> • : Ø8.8~Ø44.4mm • (Chamfering: 가) (Deburring)가 • (Back Chamfering)가 가
<p>TE45SE-□□□ -12 신제품</p>   <p>SEKT12T3AFTN-M C21</p>	 <ul style="list-style-type: none"> • : 45° <p>C36</p>	<ul style="list-style-type: none"> • : Ø25 ~ Ø32mm • 가 , (Deburring)가 • 가 “V” 가 가 • (Screw Clamp)
<p>TEF-□□□ 신제품</p>   <p>SPMT 090408 SPMT 110408 C25</p>	 <ul style="list-style-type: none"> • : 90° <p>C37</p>	<ul style="list-style-type: none"> • : Ø10 ~ Ø40mm • (Weldon) • 가 가 • (Extended Flute)
<p>TES-□□□ 신제품</p>   <p>SPMT 110408 SPMT 140508 C25</p>	 <ul style="list-style-type: none"> • : 90° <p>C38</p>	<ul style="list-style-type: none"> • : Ø50 ~ Ø100mm • 가 가 (Shell End Mill) • (Extended Flute) • (Modular) (Shell End Mill Arbor)

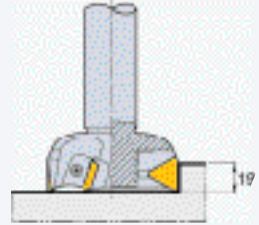

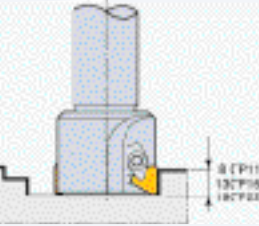
<p>LEHE□□□, -HE □□□</p>  <div data-bbox="588 488 772 766">  <p>APMT1504T-WT C15</p> <p>SPMT120408RBE C26</p> </div>	 <ul style="list-style-type: none"> • : $\varnothing 50 \sim \varnothing 80\text{mm}$ • 가 가 • (Extended Flute) • (Front Piece) • : 90° <p>C39~C40</p>	
<p>TBE□□ -□□□</p>  <div data-bbox="588 846 772 1182">  <p>SPMT 060304 RBE SDMT 090308 RBE SPMT 120408 RBE C26</p> <p>RBE**** C19</p> </div>	 <ul style="list-style-type: none"> • : $\varnothing 20 \sim \varnothing 50\text{mm}$ • (Profile) 가 • (CN 50.8) • 가 : $20.5 \sim 83\text{mm}$ <p>C41</p>	
<p>TFBE□□□ 신제품</p>  <div data-bbox="588 1384 772 1608">  <p>TBE***** B-T C26</p> </div>	 <ul style="list-style-type: none"> • : $\varnothing 10 \sim \varnothing 30\text{mm}$ • (Profile) 가 • (Straight Shank) • (Shank) 가 (ST), (), (L) <p>C42~C43</p>	
<p>HP15S-□□□</p>  <div data-bbox="588 1809 772 2033">  <p>SEKN1203EFR SEKN1203EFTR SEKN1504EFR SEKN1504EFTR C20</p> </div>	 <ul style="list-style-type: none"> • : $\varnothing 63, \varnothing 80\text{mm}$ • 가 • 가 <p>C44</p>	

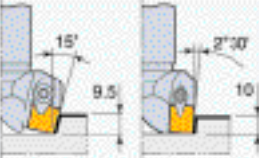

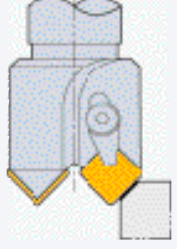



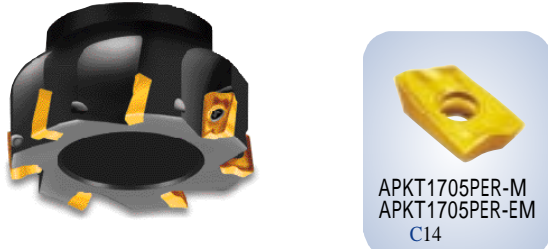
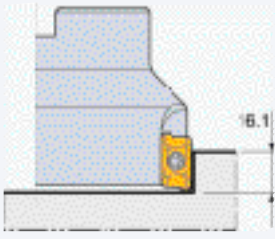

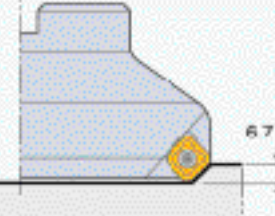
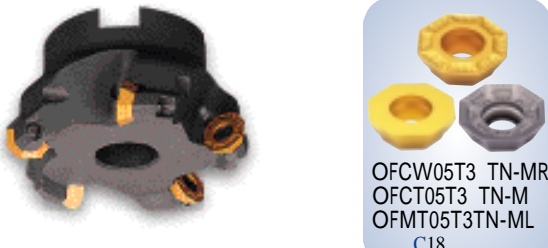
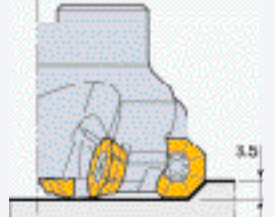
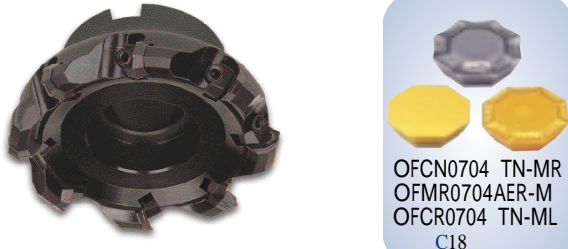
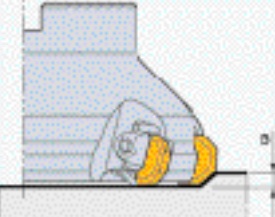

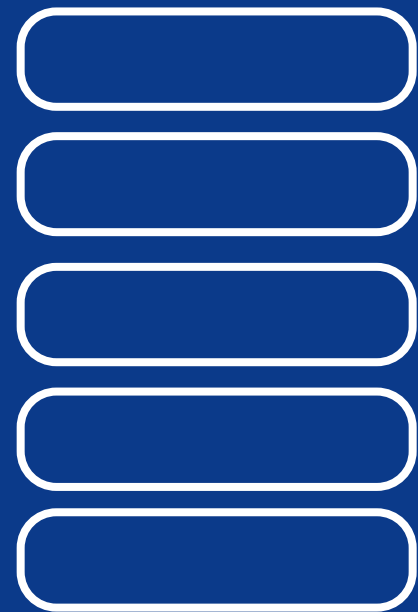
<p>HP45S-□□□-12</p>   <p>SEKN 1203AFN SEKN 1203AFTN C20</p>	 <p>• : 45° C45</p>	<ul style="list-style-type: none"> • : Ø63 • 가
<p>HP90T-□□□-22</p>   <p>TEKN2204PETR TEKN2204PER C27</p>	 <p>• : 90° C46</p>	<ul style="list-style-type: none"> • : Ø50, Ø63, Ø80mm • 가 , 가 • 가 • 가 • Body
<p>LEM-□□□</p>   <p>TPAN1103PPT/N TPAN1603PPT/N C27 TPKN2204PDTR C28</p>	 <p>• : 90° C47</p>	<ul style="list-style-type: none"> • : Ø16 ~ Ø60mm
<p>FEM50, FEM50A</p>   <p>SPGN120308 Aa59 SPKN1203 EDTR SPKN1203 EDR C24</p>	 <p>• : 75°, 87.5° C48</p>	<ul style="list-style-type: none"> • : Ø50mm
<p>KCF□□□</p>   <p>SPGN120308 Aa59</p>	 <p>• : 45° C49</p>	<ul style="list-style-type: none"> • : Ø7 ~ Ø35mm • (Chamfering:)

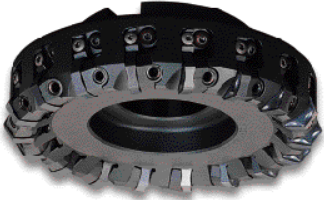
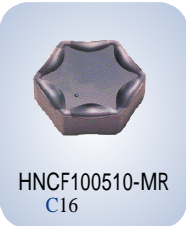
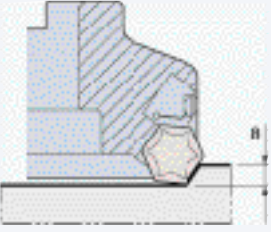

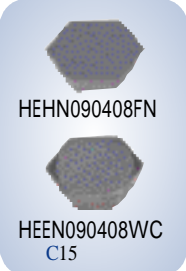
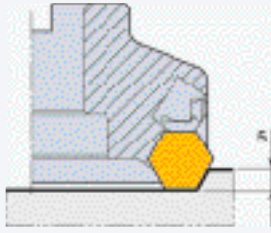
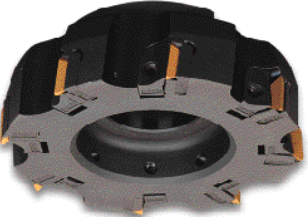
<p>TFM90AP-□□□□-17 신제품</p>  <p>APKT1705PER-M APKT1705PER-EM C14</p>	 <p>• : 90° C50</p>	<ul style="list-style-type: none"> • : Ø40 ~ Ø200mm • 가 • 가 가
<p>TFM45SE-□□□□-12 신제품</p>  <p>SEKT 12T3AFTN-M C21</p>	 <p>• : 45° C51</p>	<ul style="list-style-type: none"> • : Ø40 ~ Ø250mm • 가 • (Seat) • (Seat) (Screw Clamp)
<p>TFM43OFS-□□□□-05 신제품</p>  <p>OFCW05T3 TN-MR OFCT05T3 TN-M OFMT05T3TN-ML C18</p>	 <p>• : 43° C52</p>	<ul style="list-style-type: none"> • : Ø32 ~ Ø125mm • 가 • 8 • (Screw Clamp) • 3가
<p>TFM43OFW-□□□□-07 신제품</p>  <p>OFCN0704 TN-MR OFMR0704AER-M OFCR0704 TN-ML C18</p>	 <p>• : 43° C53</p>	<ul style="list-style-type: none"> • : Ø63 ~ Ø160mm • 8 • (Wedge Clamp) • 3가

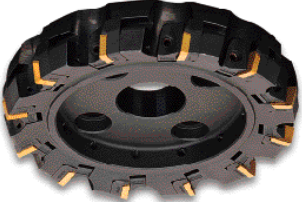

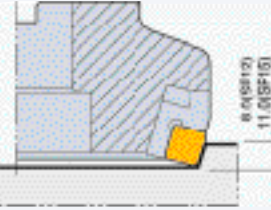

<p>M735HN-*****-10 신제품</p>   <p>HNCF100510-MR C16</p>	 <p>• : 55° C54</p>	<ul style="list-style-type: none"> • : Ø80 ~ Ø315mm • (Face Mill Cutter) • (Backlash) • 12
<p>M730HE-*****-09 신제품</p>   <p>HEHN090408FN HEEN090408WC C15</p>	 <p>• : 60° C55</p>	<ul style="list-style-type: none"> • : Ø80 ~ Ø315mm • (Wiper) 가 • 6.3S 가
<p>M400TP-*****-16/22B</p>   <p>TPKN1603PPR TPKN1603PPTR TPKN2204PDR TPKN2204PDTR C28</p>	 <p>• : 90° C56~ C57</p>	<ul style="list-style-type: none"> • : Ø50 ~ Ø315mm • 가 • 가
<p>M415SP-*****-12/15</p>   <p>SPEX1203 EDR-1 SPKN 1203 EDR SPKN 1203 EDTR SPKN1504 EDR SPKN 1504EDTR C24</p>	 <p>• : 75° C58~ C59</p>	<ul style="list-style-type: none"> • : Ø80 ~ Ø315mm • 가 • 가

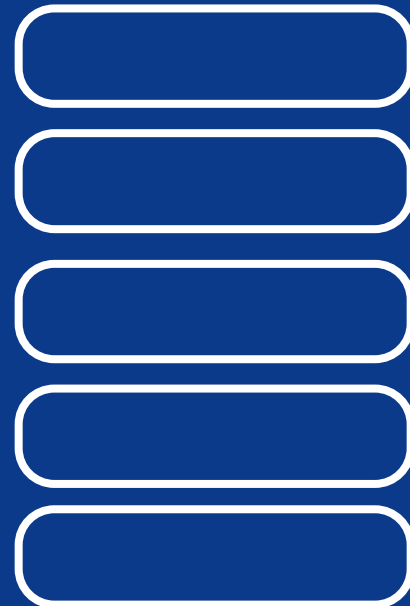
C

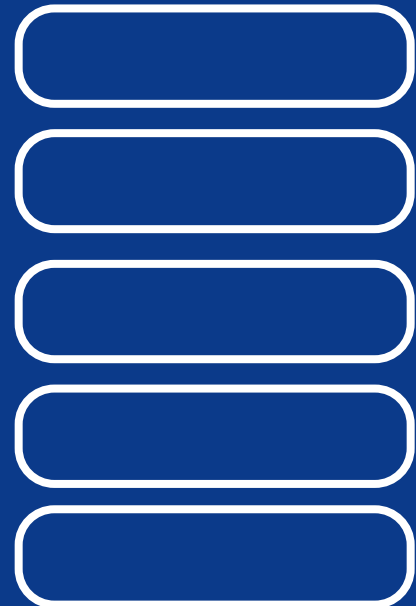

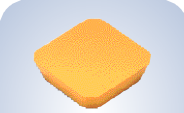
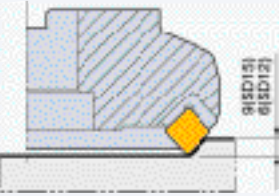
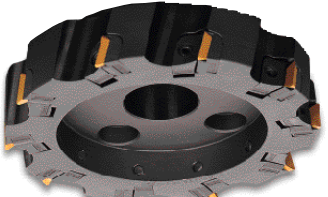
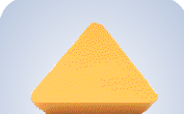
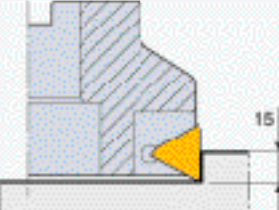

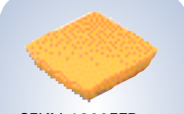
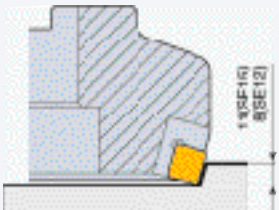
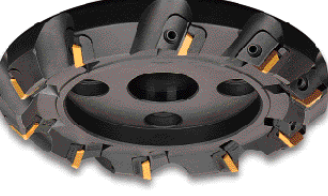
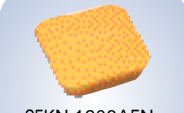
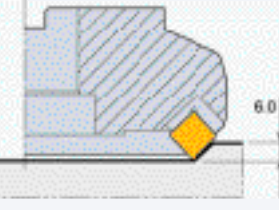
<p>M445SD-*****-12B/15B</p>   <p>SDKN1203M SDKN1203MT SDKN1504M SDKN1504MT C19</p>	 <p>• : 45° C60~C61</p>	<ul style="list-style-type: none"> • : Ø80 ~ Ø250mm • 가 • 가
<p>M500TE-*****-22B</p>   <p>TEKN 2204PETR TEKN 2204PER C27</p>	 <p>• : 90° C62</p>	<ul style="list-style-type: none"> • : Ø80 ~ Ø200mm • , 가 • 가
<p>M515SE-*****-12B/15B</p>   <p>SEKN 1203EFR SEKN 1203EFTR SEKN 1504EFR SEKN 1504EFTR C20</p>	 <p>• : 75° C63~C64</p>	<ul style="list-style-type: none"> • : Ø80 ~ Ø250mm • , 가 • 가
<p>M545SE-*****-12B/15B</p>   <p>SEKN 1203AFN SEKN 1203AFTN SEKN 1504AFN SEKN 1504AFTN C20</p>	 <p>• : 45° C65~C66</p>	<ul style="list-style-type: none"> • : Ø80 ~ Ø250mm • 가 • 가

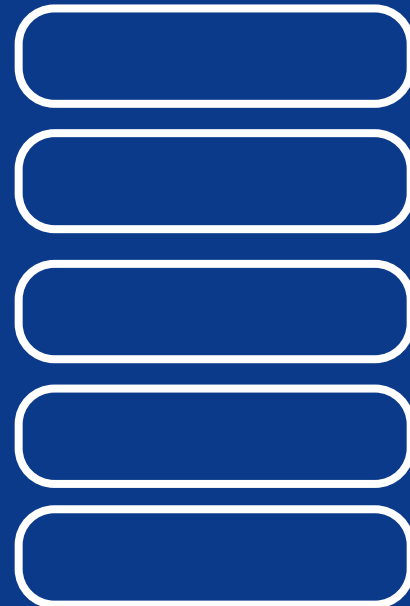

<p>KQQNA 63 ***** 신제품</p>   <p>HNCF100510-MR C16</p>	 <p>• : 55° C68</p>	<ul style="list-style-type: none"> • : Ø200 ~ Ø400mm • (Quick Change Milling Cutter) • (Face Mill Cutter) • 12
<p>KQQEA *****</p>   <p>HEHN090408 FN HEEN090408 WC C15</p>	 <p>• : 60° C69</p>	<ul style="list-style-type: none"> • : Ø200 ~ Ø400mm • 가 : 6.3S • 가 (Wiper)
<p>KQLN 44 ***** , KQLN 54 *****</p>   <p>LNE324-05 LNE434-02 C17</p>	 <p>• : 45° C70</p>	<ul style="list-style-type: none"> • : Ø200 ~ Ø400mm • (Quick Change Milling Cutter) • 가
<p>KQGN 44 *****</p>   <p>SNKN1204EN C23</p>	 <p>• : 45° C71</p>	<ul style="list-style-type: none"> • : Ø80 ~ Ø400mm • (Quick Change Milling Cutter)
<p>KQHF 54 *****</p>   <p>SFCN1504ZFN C22</p>	 <p>• : 45° C72</p>	<ul style="list-style-type: none"> • : Ø100 ~ Ø400mm • (Quick Change Milling Cutter)

* KQYP, KQGN, KQFN, KQYE 가 . ()